



**Engine Rebuilding Equipment, Inc.**

5775 Bridgeview Center

Saginaw, Mi 48604

Web Site: [www.rmcengine.com](http://www.rmcengine.com)

**USA & Canada**

Phone

Fax

**(800) 248-5062**

**(989) 754-3611**

**(989) 754-1696**



# Hydraulic Crankshaft Grinders



**RMC-1500HD** shown above

RMC Crankshaft Grinders are designed with state-of-the-art technology to utilize the most accurate and efficient crankshaft setup system available. RMC's built-in features benefit the serious rebuilder who is grinding welded crankshafts or crankshafts with special stroke requirements. High performance Engine Builders particularly appreciate the ability to modify or maintain the existing stroke with the utmost accuracy and repeatability.

***Dedicated to serving your engine rebuilding equipment needs.***

## RMC Crankshaft Grinders are ... Fast ... Accurate ... Dependable

RMC Crankshaft Grinders use work heads with 4-way cross slides with an advanced locking system which permits quick centering of the crankshaft. Heavy duty one piece cast iron construction assures you a lifetime of superior accuracy and dependability. Whatever your crank grinding needs, RMC has a model designed to do the job that your customers demand - at a price that you can afford.

SPECIFICATIONS	RMC 1200	RMC 1500
Distance between centers	52.00"	61.00"
Distance between chucks	50.00"	60.00"
Height of centers over table	8.60"	9.80"
Swing over table	17.30"	19.70"
Max offset of centers	3.10"	4.00"
Max grinding diameter	7.10"	8.10"
Fast hydraulic wheelhead traverse	3.10"	4.50"
Hand wheelhead feed distance	5.90"	6.50"
Hand wheelhead feed graduations	0.0002"	0.0002"
Wheelhead feed per revolution	0.04"	0.04"
Table traverse handwheel revolution	0.44"	0.50"
Fast hydraulic table traverse	118"/min.	118"/min.
Grinding wheel speeds	1000-1150 rpm	900-1000 rpm
Max grinding wheel diameter	24.00"	28.00"
Max width of grinding wheel	2.50"	2.75"
Diameter of chucks	7.10"	7.10"
Chuck hold diameter	8.60"	8.60"
Steady rest capacity	1-3.00"	1-3.94"
Workhead spindle speeds	35-70 rpm	20-30-40-60 rpm
Max weight on centers	440 lbs	440 lbs
Max weight on rests	660 lbs	1,100 lbs
Wheelhead motor	5 hp	7 hp
Wheelhead spindle motor	1/2 - 3/4 hp	3/4 - 1 hp
Hydraulic power motor	1 hp	1 hp
Cooling pump	1/12 hp	1/12 hp
Length	129"	157"
Height	53"	59"
Width	61"	66"
Work space required	181 x 59"	219 x 55"
Net/Shipping weight	6173 / 7055 lbs	7275 / 8378 lbs
Shipping box size	118 x 59 x 67"	142 x 64 x 70"

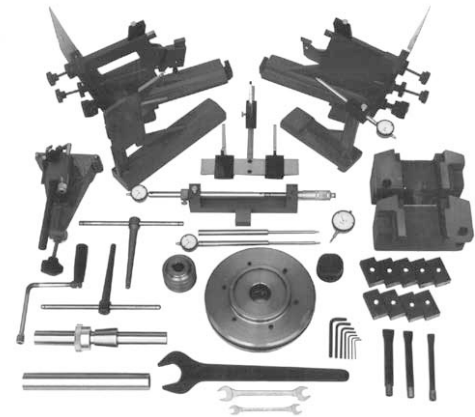

### Standard Equipment

Grinding wheel & hub, narrow steady rest w/dial indicator, universal steady rest (1500), device for setting length of stroke, throw setting device, set up device w/dial indicator, dresser w/diamond, wheel balancing arbor, pair extra counterweights, grinding motor reduction pulley, pair coolant nozzles and set of wrenches, service tools and operator's manual.



**Massive Head and Tail Stocks feature face plate system** with positive stop and trim adjustment to make short work of setup time. Shown below with steady rest.



Shown above is the optional hydraulic face dresser

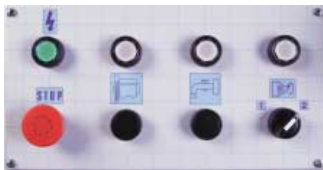

**Control panel** is conveniently located for fast easy access throughout the grinding operation.



**RMC's grinding system** (shown with the guard door open) utilizes a heavy duty spindle assembly. Combined with the proper coolant flow over the work piece, prevents wheel loading and poor grinding results.

In order to bring you the most advanced features as soon as possible, all features, descriptions and technical specifications are subject to change.

# RMC

**RMC Engine Rebuilding Equipment, Inc.**

5775 Bridgeview Center  
Saginaw, Mi 48604  
Web: [www.rmcequipment.com](http://www.rmcequipment.com)

USA/Canada  
Phone  
Fax

(800) 248-5062  
(989) 754-3611  
(989) 754-1696